

CHICAGO PARK DISTRICT
 541 NORTH FAIRBANKS
 Chicago, Illinois 60611

BOOTH HANSEN

Architecture - Interiors - Planning
 338 South Des Plaines Street
 Chicago, Illinois 60661

ISSUED FOR ADDENDUM #1	08/27/09
ISSUED FOR CONST. DOCUMENTS 100%	08/05/09
ISSUED FOR CONST. DOCS. 90% / PERMIT	07/22/09
ISSUED FOR CONST. DOCUMENTS 60%	06/26/09
ISSUED FOR DESIGN DEVELOPMENT	06/05/09
ISSUED FOR SCHEMATIC DESIGN	05/18/09
	03/13/09

REVISIONS DATE

PROJECT MANAGER	
PROJECT MANAGER	
DIRECTOR OF ENGINEERING	

PROJ. MGR.:	GH
DESIGNER:	LB/SC/BB
DRAWN:	SC/BB
CHECKED:	LB/GH/CS
SCALE:	NOTED
DATE:	AUGUST 2009
SPEC. NO.:	XXXX-XX
JOB NO.:	0824.00

SHEET INFORMATION



VALLEY FORGE PARK
 7001 W. 59TH STREET
 CHICAGO, IL 60638
 PARK #371

PARK NO./PROJECT NO.
 0824.00

DOOR DETAILS

A602
 DRAWING NO.

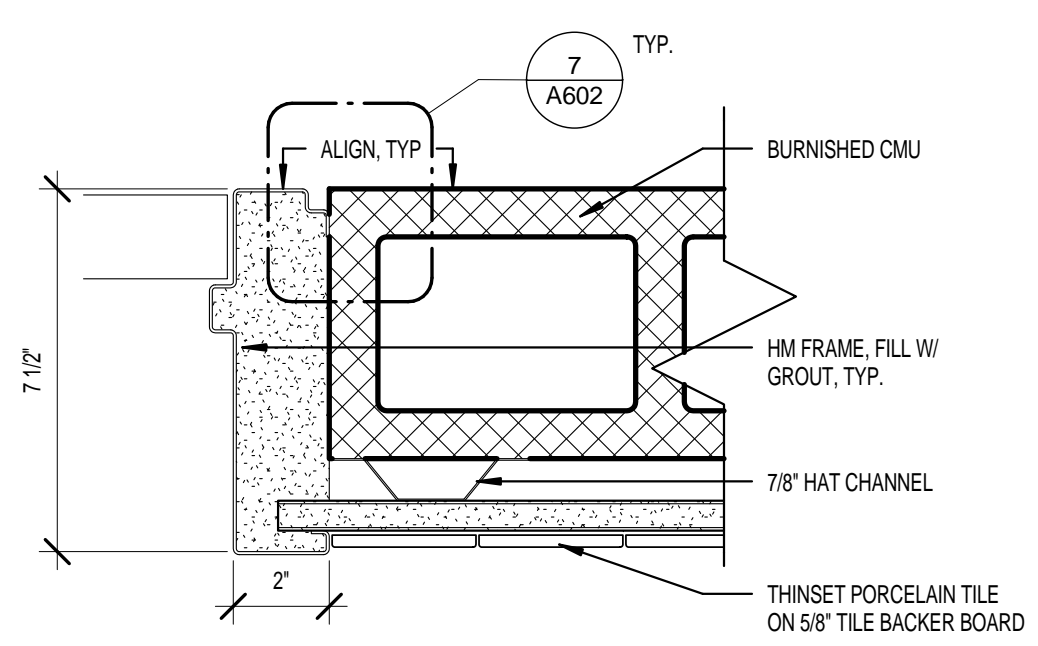

3a DR JAMB DETAIL - CMU - TOILET RM

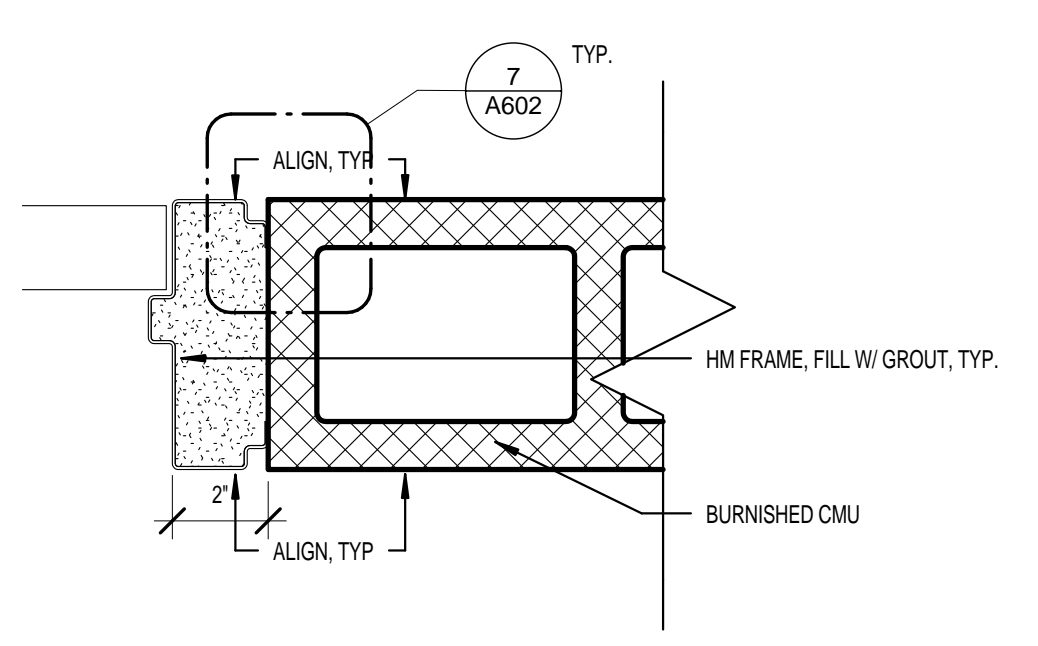

3 DR JAMB DETAIL - CMU OPENING

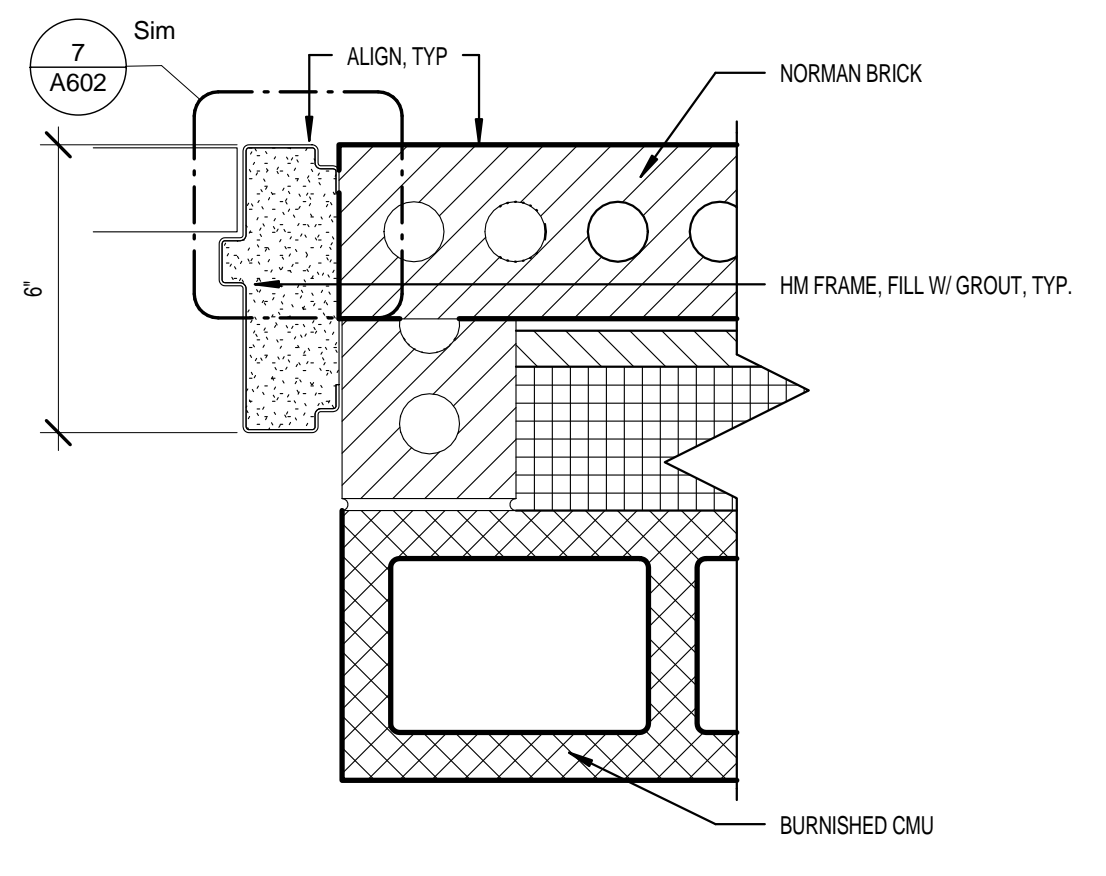

2 DR JAMB DETAIL - EXT. MASONRY OPENING

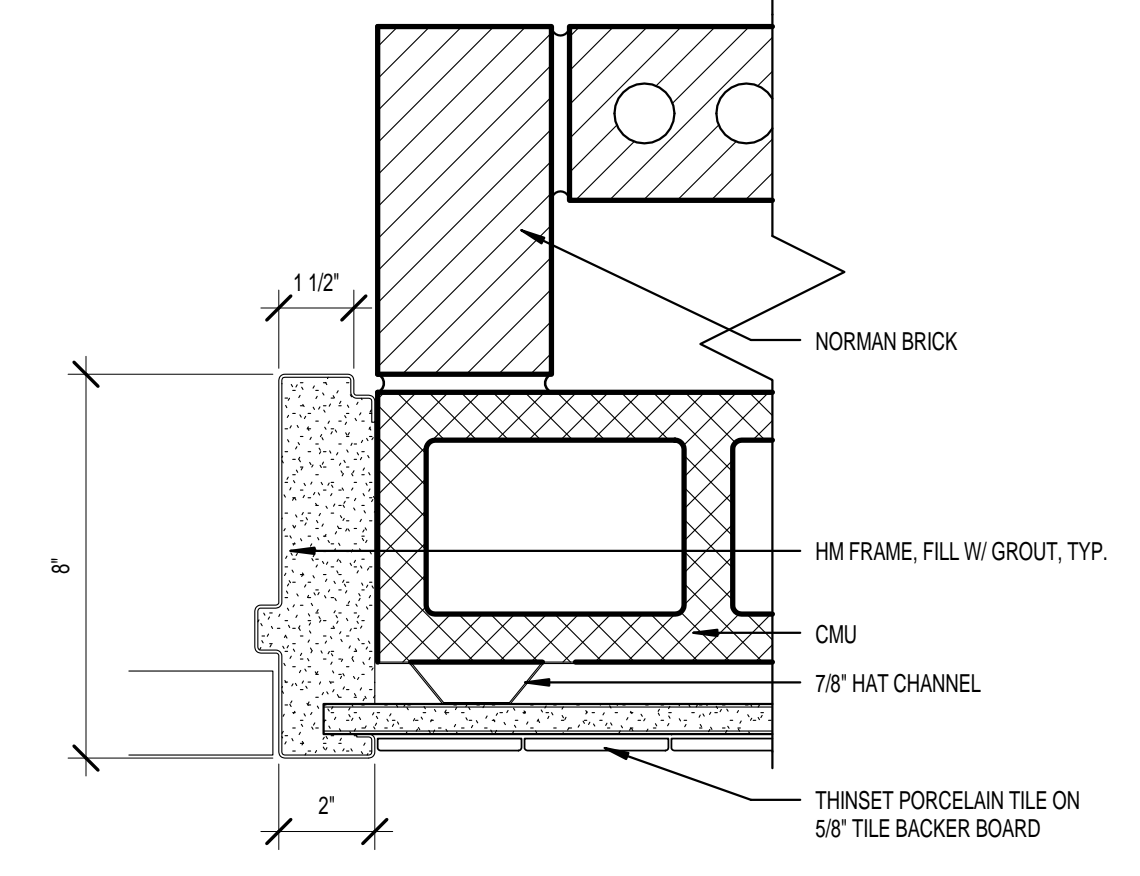

1a DR JAMB DETAIL - MASONRY @ TOILET RM

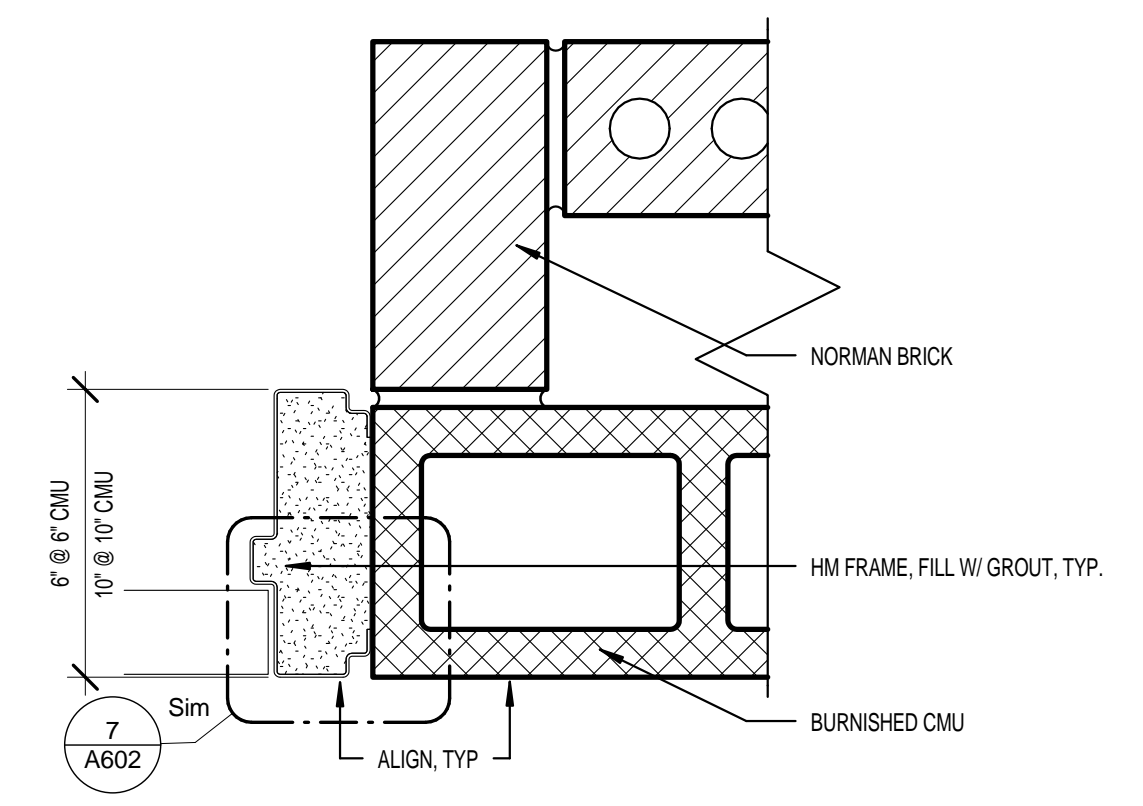

1 DR JAMB DETAIL - MASONRY OPENING

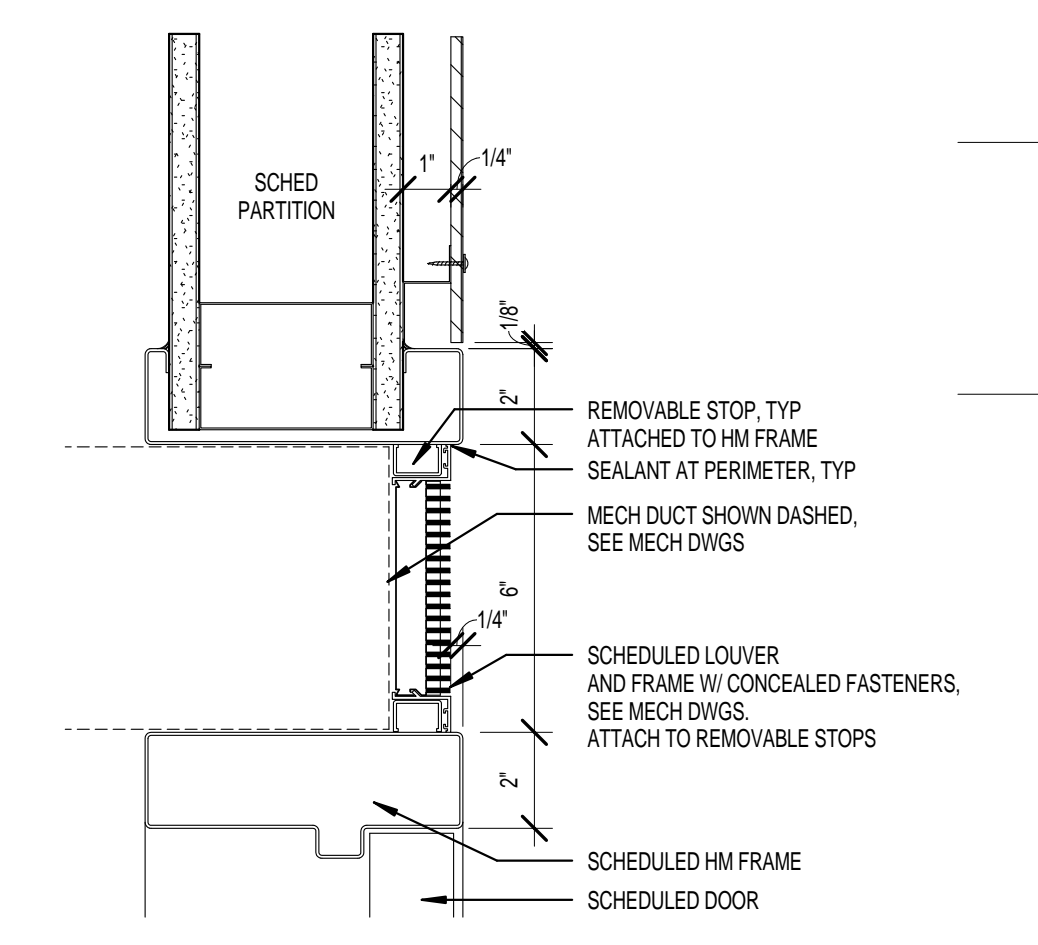

8a SECTION DETAIL - LINEAR DIFFUSER AT FRAME TYPE 5

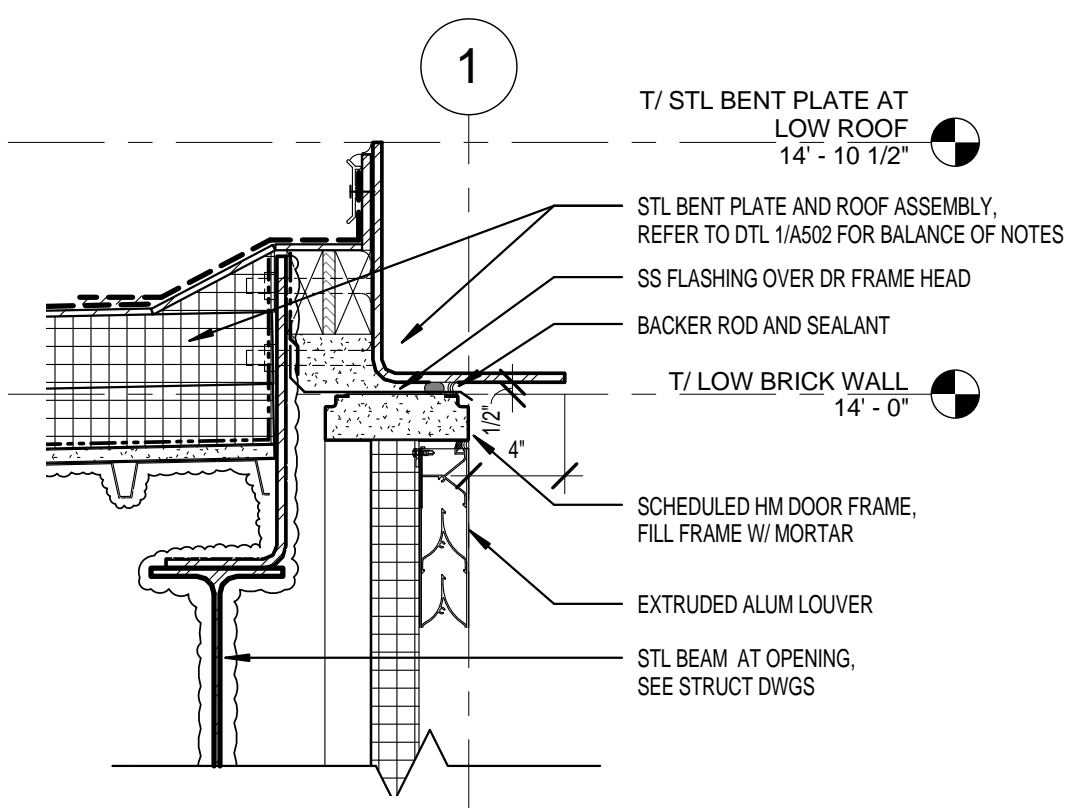

1

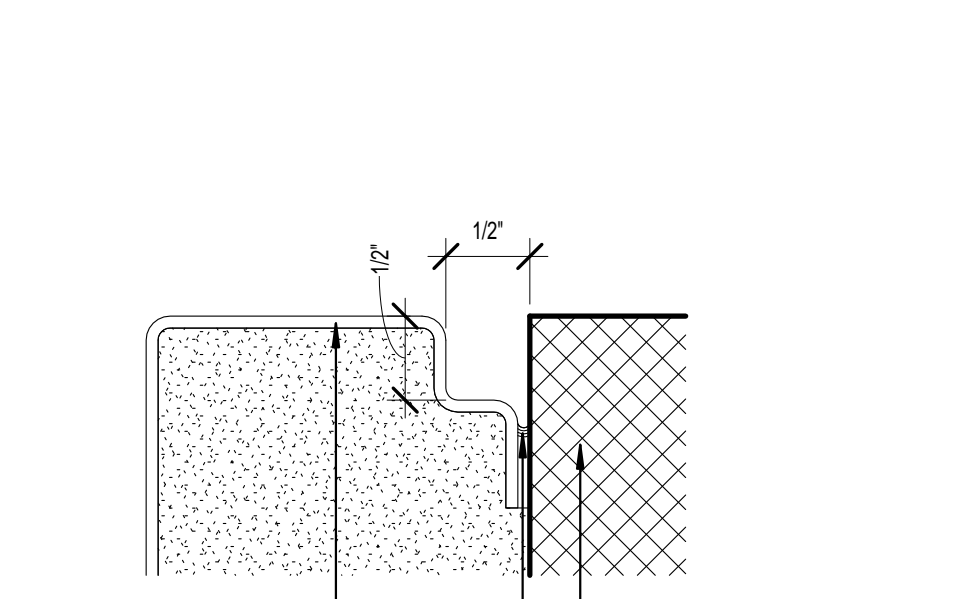

7 DTL @ DOOR JAMB

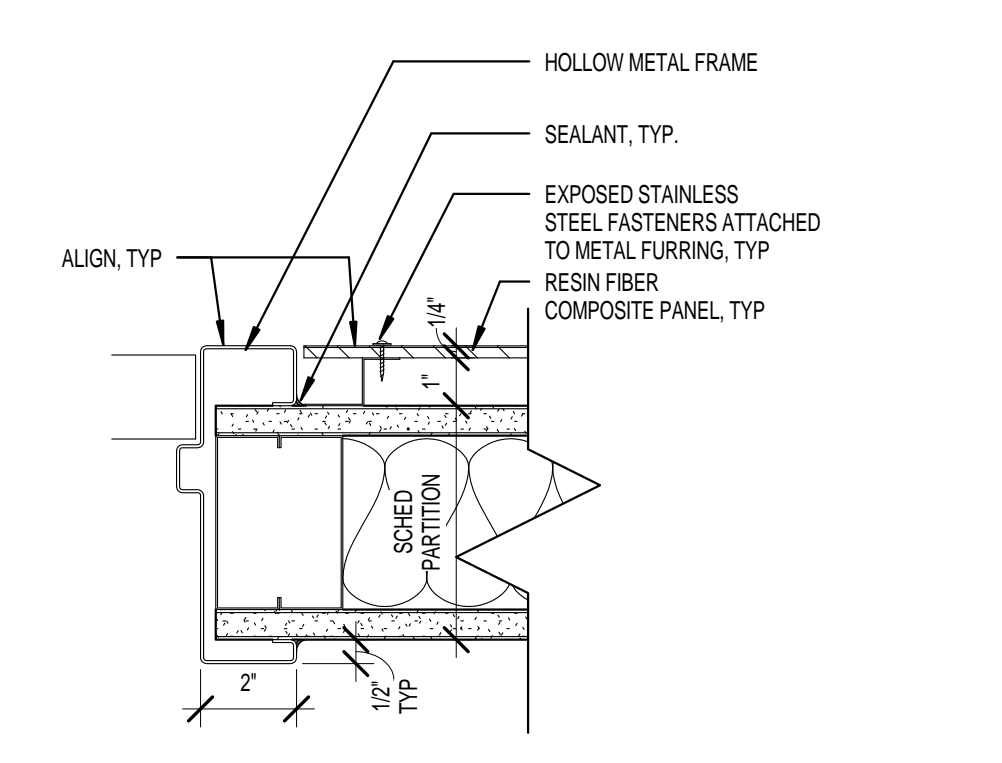

5 DR JAMB DETAIL - RESIN BD ONE SIDE

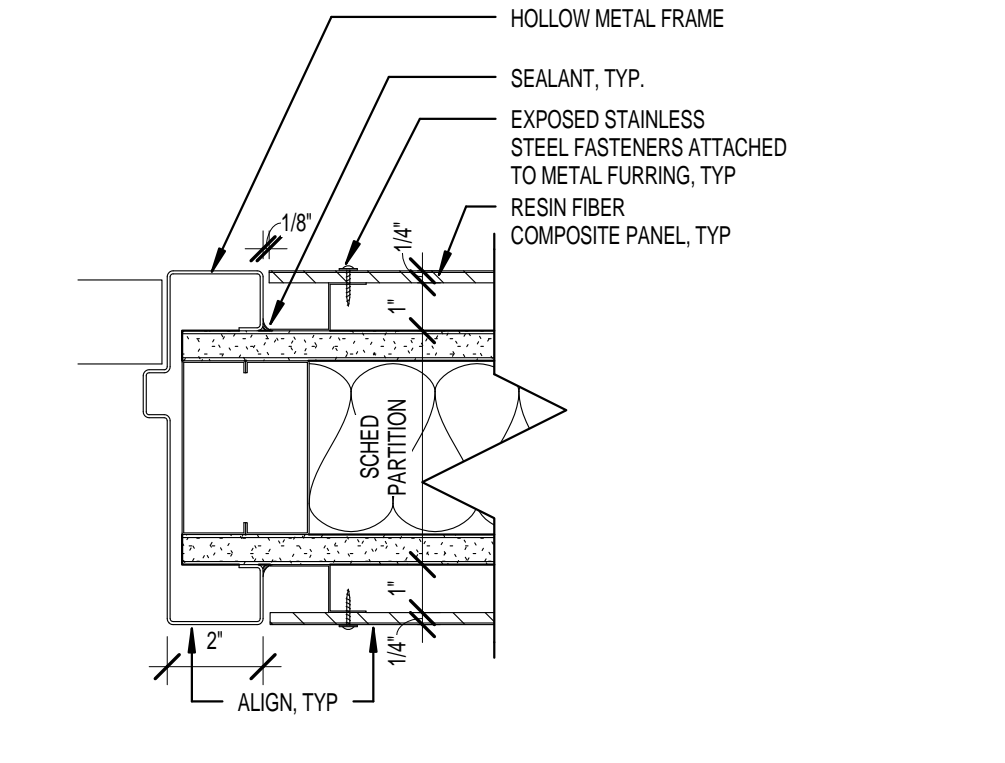

4 DR JAMB DETAIL - RESIN BD BOTH SIDES

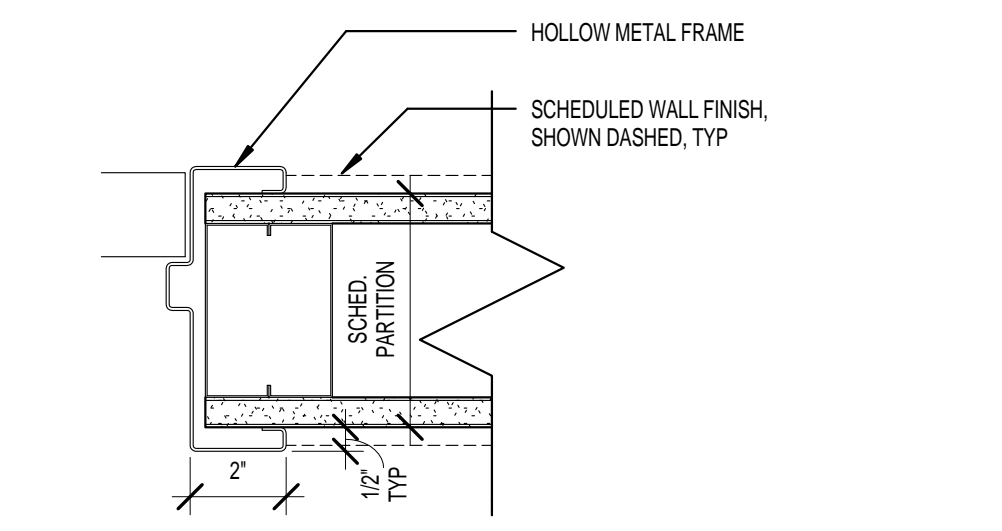

6 DR JAMB DETAIL - TYP GYP BD PARTITION

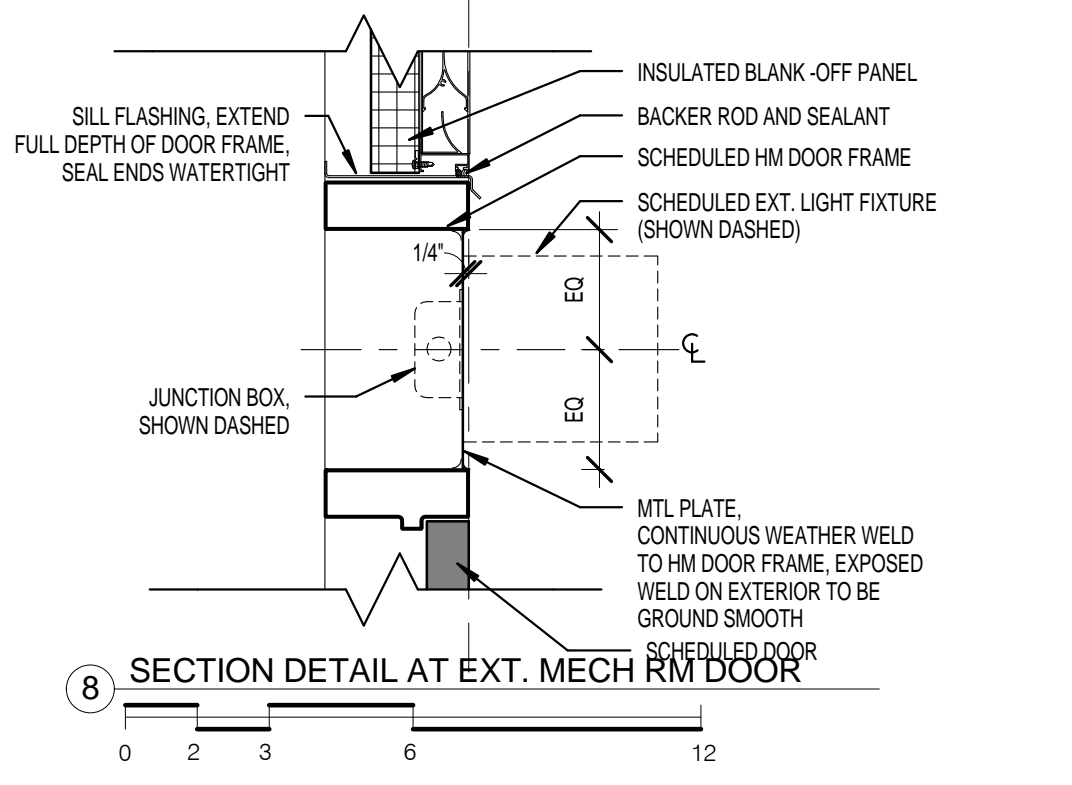

8 SECTION DETAIL AT EXT. MECH RM DOOR

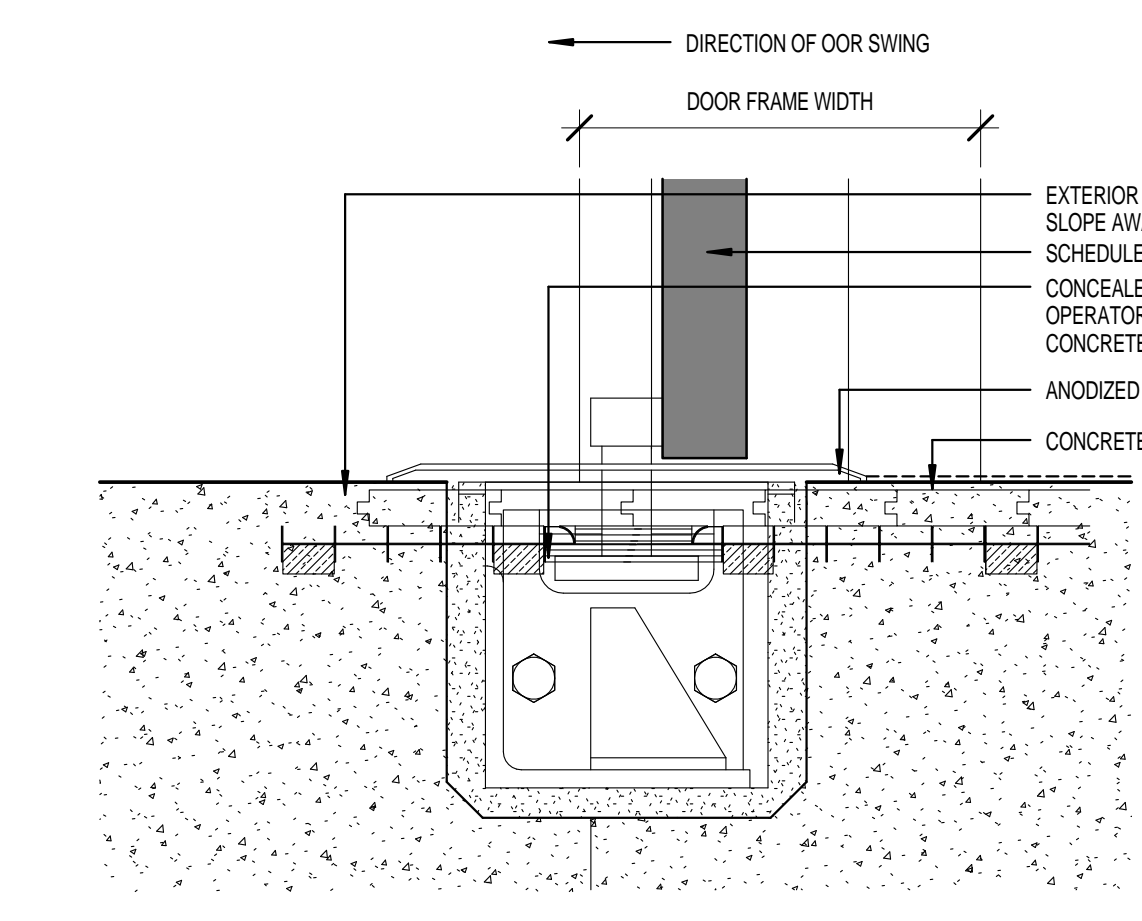

13 DR THRESHOLD DETAIL - EXTERIOR DOOR W/ CLOSER

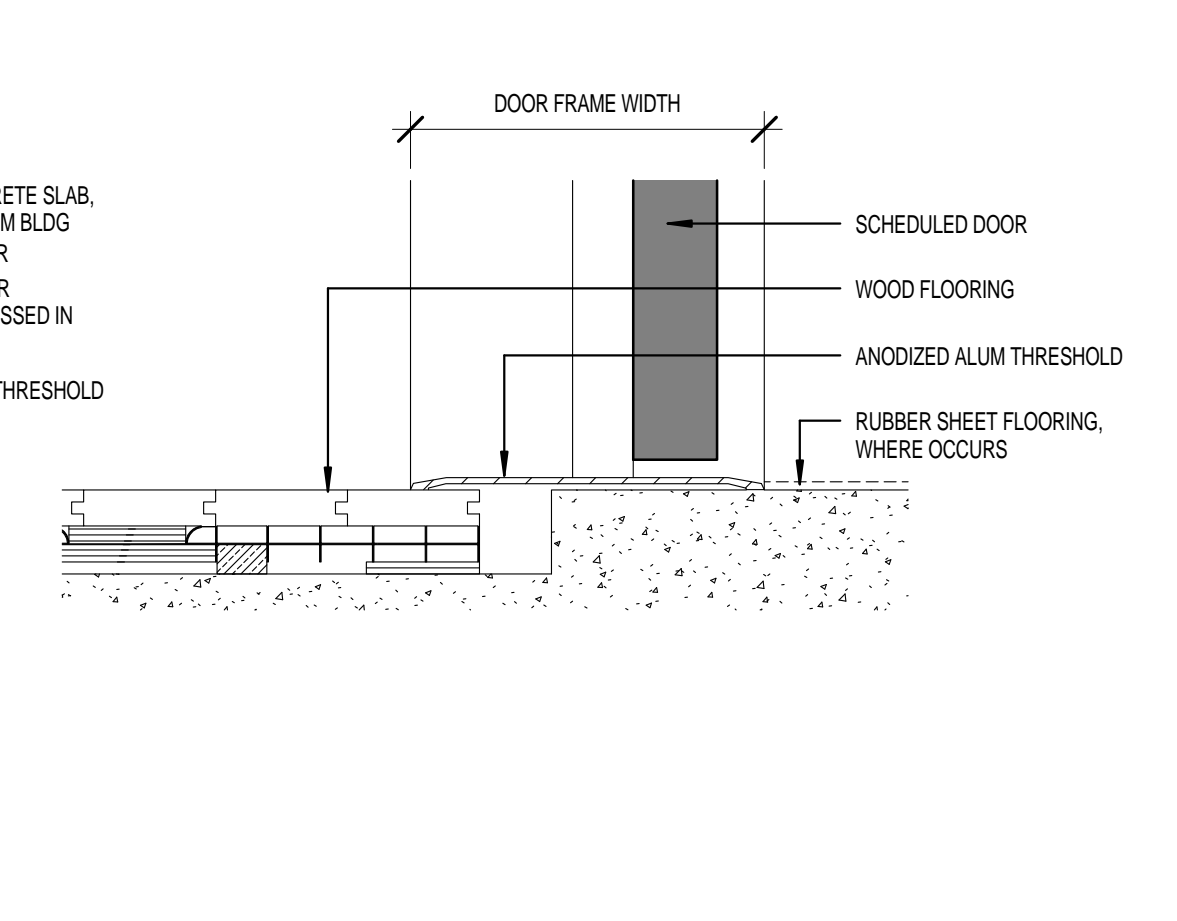

12 DR THRESHOLD DETAIL - WOOD FLOORING TO RUBBER/CONC.

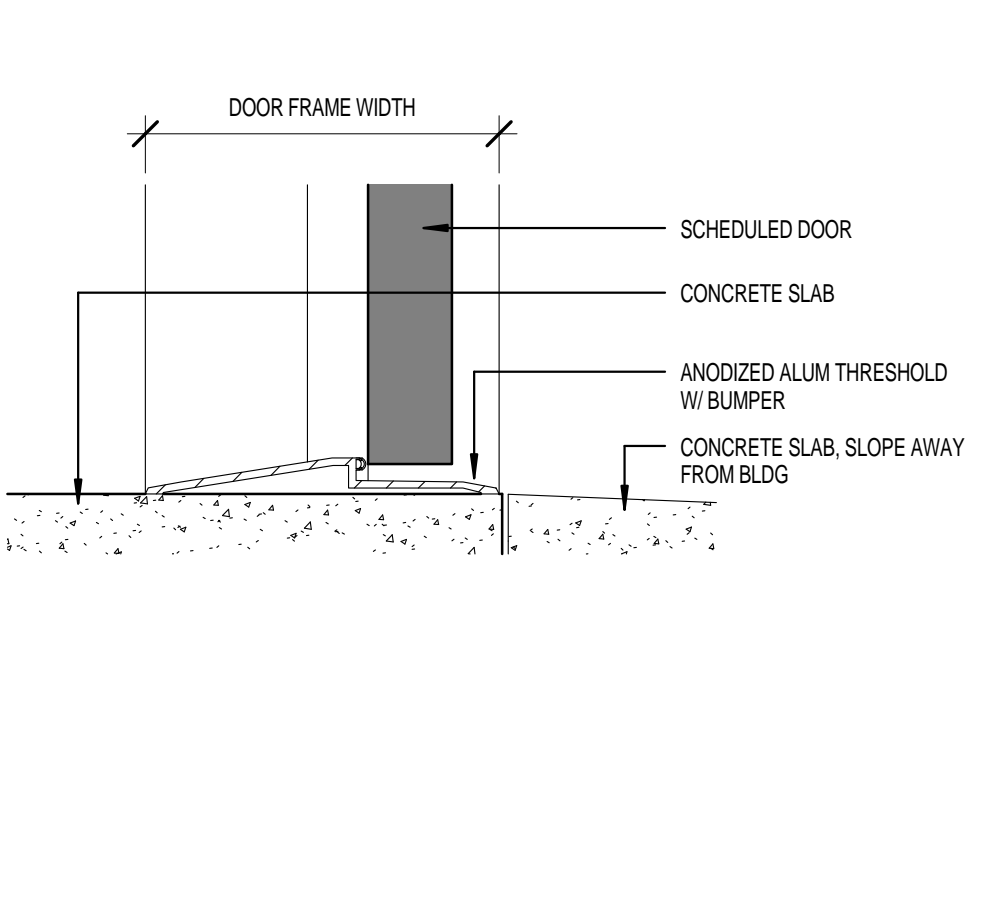

11 DR THRESHOLD DETAIL - EXTERIOR DOOR

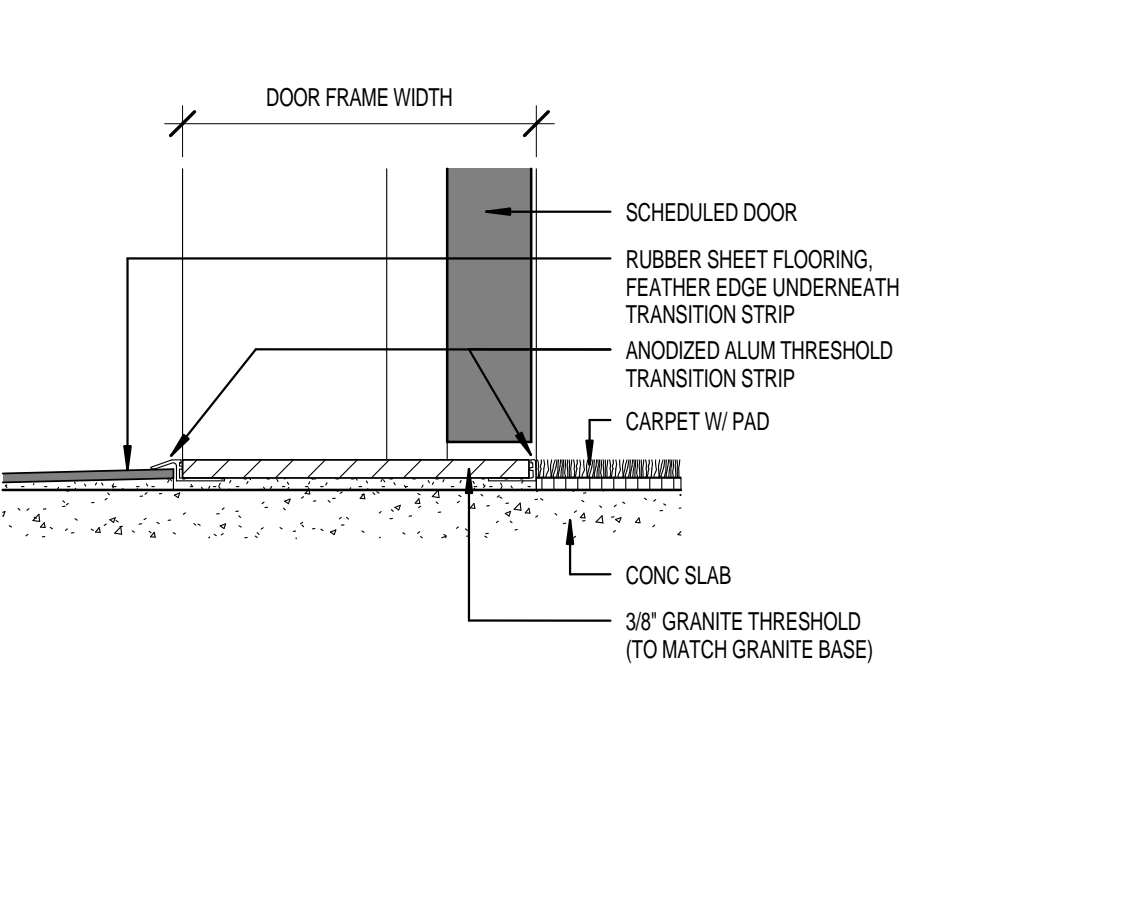

10 DR THRESHOLD DETAIL - RUBBER TO CARPET

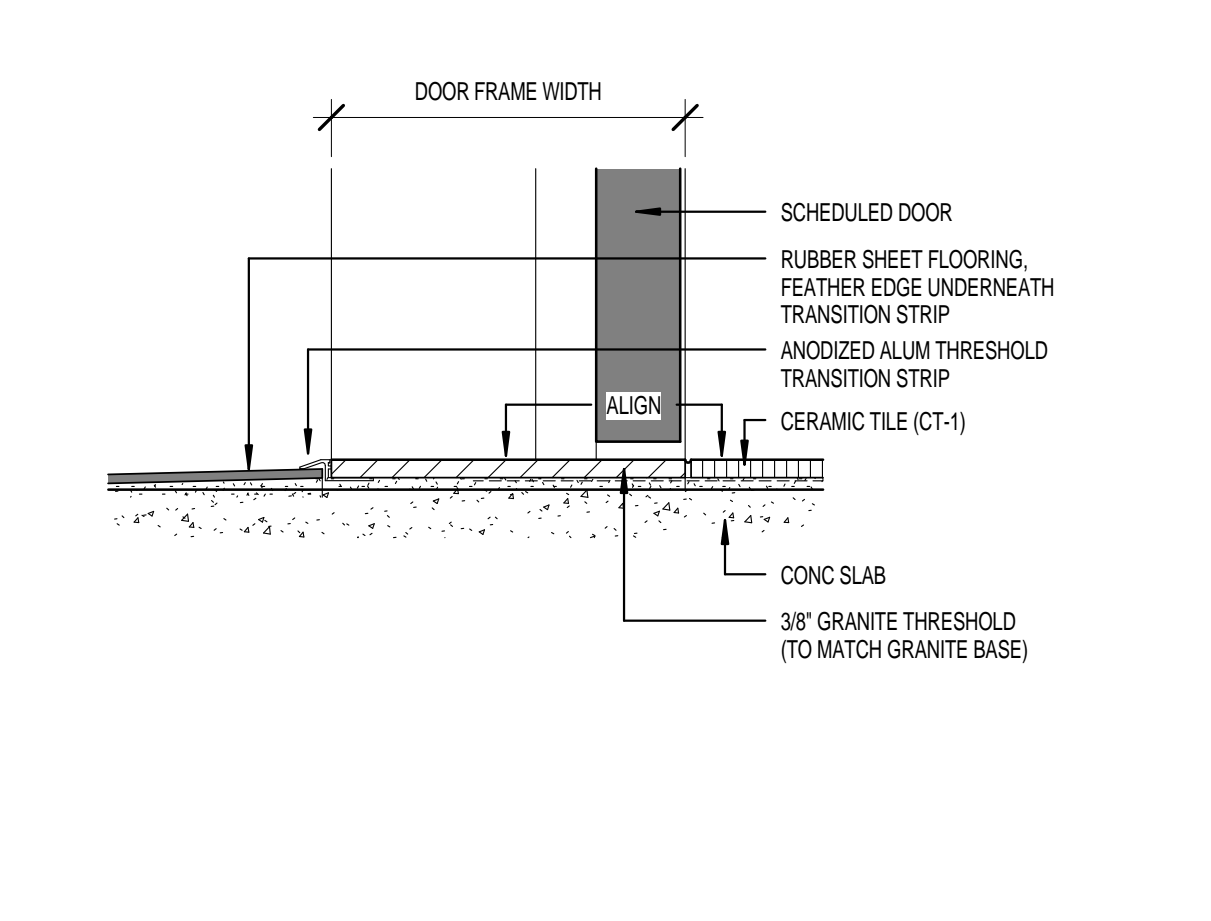

9 DR THRESHOLD DETAIL - RUBBER TO CERAMIC TILE